



Hinged hand trolley with automatic locking.

Properties

- Can be mounted on rails easily and very quickly.
- With wheel fracture support device.
- Maximum beam thickness for type A1=28 mm and A2/A3 = 30 mm.

Norm:

- EN12100-1/2, EN13157, EN2018, EN2009

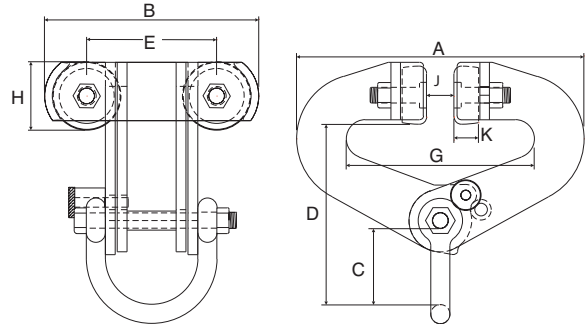

Alternative see type RMSLT Page 43

Type	WLL (kg)	Jaw opening (mm)	A (mm)	B (mm)	C (mm)	D (mm)	E (mm)	G (mm)	H (mm)	J (mm)	K (mm)	Weight (kg)	ProductId
A1	3000	76-230	380	280	110	250	170	76-230	82	30	32	21	3512001
A2	6000	100-305	500	296	110	290	170	100-305	88	40	38	33	3512003
A3	10.000	100-305	580	290	135	310	170	100-305	109	40	38	47.5	3512005

Superclamp serial BA

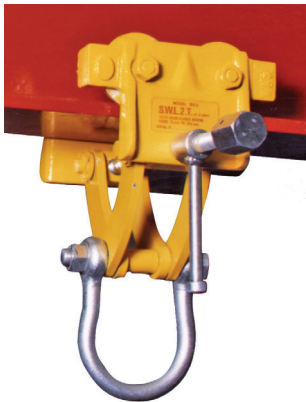

Adjustable spindle hand trolley with rod-type securing nuts.

Properties

- Compact design and low tare weight.
- Can be mounted quickly by means of a spindle.
- Rod-type securing nuts for added safety.
- With wheel fracture support device.
- Maximum beam thickness for type A1=28 mm and A2/A3 = 3 mm.

Norm:

- EN12100-1/2, EN13157, EN2018, EN2009

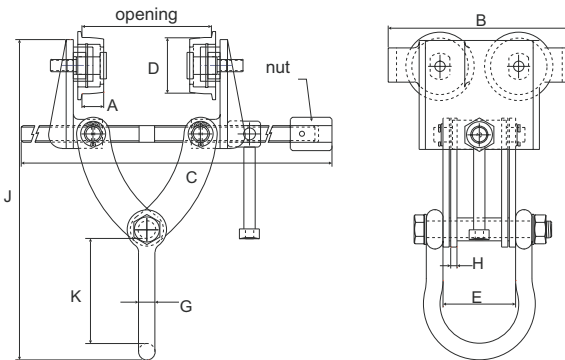

Alternative see type RMBT-2 Page 43

Type	WLL (kg)	Jaw opening (mm)	A (mm)	B (mm)	C (mm)	D (mm)	E (mm)	G (mm)	H (mm)	J (mm)	K (mm)	Weight (kg)	ProductId
BA1	1000	63-203	14	176	360	46	70	16	6	309	101	6.5	3513001
BA2	1500	76-203	21	176	360	54	70	16	6	309	101	7.2	3513003
BA3	2000	76-203	21	176	360	54	70	16	8	309	101	7.2	3513005

Superclamp B serial